

V Stage Chain Block

Line draft diagram

Safe

Double pawl and automatic fail-safe brake device are safe and reliable.

The up and down hooks are forged and have safety latch.

Quality

Durable friction discs.

The heat-treated large plate, various gears and long and short shafts have higher strength.

Hooks and chains are quenched and tempered.

Chain surface galvanized treatment.

Design

Equipped with a uniquely designed chain guide wheel.

The surface is treated with powder paint.

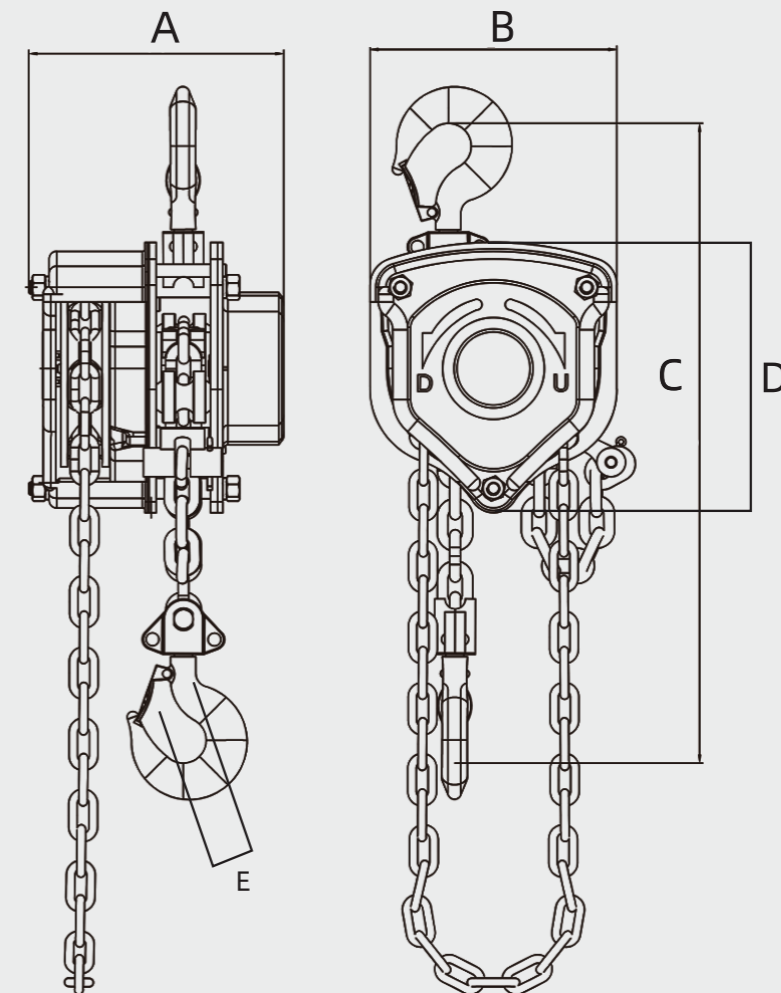

Capacity (kg)	Running test load (kg)	Lifting height (m)	Load chain Dia (mm)	No. of falls load chain	Dimension (mm)					G.W (kg)
					A	B	C	D	E	
1000	1500	≥6	6.3	1	150	150	360	155	28	12
2000	3000	≥6	8	1	180	210	420	220	32	20