

STAGE ELECTRIC CHAIN HOIST
Kyra D8 PLUS 1000kg
舞台电动葫芦



型号/MODEL: D8 PLUS 1000

起升速度/LIFTING SPEED: 4M/MIN

起升重量/SAFE WORKING LOAD: 1000KG

Kyra D8 PLUS 1000kg 舞台电动葫芦依照DGUV V54标准符合D8 PLUS标准

Kyra D8 PLUS 1000kg STAGE ELECTRIC CHAIN HOIST WITH DGUV V54 D8 PLUS STANDARD

📍 地址:北京市海淀区金隅嘉华D座1005室

🏢 Manufacturer: JDP China Drive Systems Co., Ltd

✉ Email:admin@jdp.top

☎ 电话:+86 13720022523

☎ TEL:+86 13720022523

🌐 网址:www.jdp.top

🌐 Website: www.jdp.top

CONTENTS 目录

1.产品简介	3
2.技术数据	4
2.1.标准配置	4
2.2.选装配置	4
2.3.线形图	5
2.3.产品爆炸图	8
3.电器数据	10

1.PRODUCT INTRODUCTION	3
2.TECHNICAL DATA	4
2.1.STANDARD VERSION	4
2.2.OPTIONAL CONFIGURATION	4
2.3.LINE GRAPH	5
2.3.PRODUCTS EXPLOSION VIEW	9
3.ELECTRICAL DATA	10

产品简介 Product Introduction



- 机身坚固, 外观小巧、时尚, 搬运方便
- 表面哑光黑处理, 避免光污染, 使用更方便
- 动力强劲, 运行灵活稳定
- 整机防护等级IP66, 可在雨中作业
- 100级链条, 8倍安全系数
- 配有5个链窝链轮的精密导链器, 运行更顺滑
- 斜齿齿轮传动, 齿轮等级6级, 运行噪音≤60分贝
- 下钩吊环设计, 配合卸扣使用更安全
- 尼龙导链器, 确保链条运行顺畅
- 铝合金一体外壳, 并经过热处理, 机身坚固, 降低机身重量
- 搭配获得专利的摩擦离合器, 用于过载保护
- 电磁刹车制动, 安全性更高
- 链条袋经过特殊设计, 无需拆卸, 可轻松实现倒挂
- 滑动离合器位于电动机和制动器之间, 能很好地控制住传动部件。即使离合器磨损严重或损坏, 负载也不会失去控制坠落, 因为负载可以被制动器固定在任何位置。
- 离合器采用非石棉材质。
- Rugged shell, small, fashion, easy to carry
- Matte black treatment surface, avoid light pollution, more convenient to use
- Strong power, flexible and stable operation
- Protection grade IP66, can work in the rain
- G100 load chain, 8 times safety factor
- Precision chain guide with 5 pocket sprockets for smoother operation
- Helical gear transmission, gear grade 6, operating noise ≤60 db
- The lower hook ring design, more safe to use with the shackle
- Nylon chain guide for smooth chain operation
- Heat treatment aluminum alloy integrated shell, the rugged shell, reducing the weight of the fuselage
- With patented friction clutch for overload protection
- Electromagnetic brake, higher safety
- Specially designed chain bag without disassembly and can be easily hung upside down
- The sliding clutch is located between the motor and the brake so that the power from the brake to the load is transmitted by gear parts in form-fitting connection. Even if the clutch is seriously worn, the load will not fall uncontrolled as the load can be held in every position by the brake.
- Clutch is made of non-asbestos material.

标准配置:

- 设备型号: D8 PLUS 1000
- 起重量符合 DGUV V54 (D8 PLUS): 1000Kg 双刹车
- 提升速度(m/min): 4
- 直接控制: 380-415V、3ph、50/60Hz;
220-230V、3ph、50/60Hz (见图6,P10)
- 1m电缆, 带CEE-16 / 4
- 链条尺寸 EN818-7(mm): 7.4*21
- 链条重量 (Kg/m): 1.2
- 链条的动态安全系数: 最小值 5:1
- 链条等级: G100
- 链条表面: 磷化(黑)
- 导链器: 带有5个链窝链轮的精密导链器
- 链条行数: 1
- 链条袋: 1纺织链条袋, 可拆卸, ≤30米
- 离合器: 获得专利的摩擦离合器, 用于过载保护
- 满载噪音(dB): ≤60
- 制动器: 2个直流制动
- 吊钩: 1个下(可旋转)
- 悬挂方式: 吊环悬挂
- 安装方式: 自爬或固定
- 塑料手柄: 无
- 防护等级: IP66
- 不含链条的重量(kg): 31
- 电机功率(KW): 1.1
- 电流消耗(A): 2.7
- 机械等级/FEM9.511: 1Bm/25% ED
- 颜色: 黑色, 色号RAL 9005 哑光

选装配置:

- **电子限位 选装** 内部调节机械旋转电子限位
- **电子限位 选装** 直接调节上下电子触点限位(见图8,P11)
- **编码器 选装** 安装增量式编码器或预留编码器安装位(低速链轮输出轴或高速电机轴)
- **悬挂方式 选装** 旋转吊钩(见图3,P6)
- **称重检测 选装** 称重传感器
- **链条表面处理 选装** 镀锌(白)

STANDARD VERSION:

- MODEL: D8 PLUS 1000
- SWL acc. DGUV V54 (D8 PLUS): 1000Kg double brake
- Lifting Speed (m/min): ca. 4
- Direct Control : 380-415V、3ph、50/60Hz;
220-230V、3ph、50/60Hz (See Figure 6,P10)
- 1m Cable with CEE-16/4
- Chain acc. EN818-7 (mm): 7.4*21
- Chain net weight (Kg/M): ca. 1.2
- Dynamic safety factor for chain: min. 5:1
- Grade of chain: 100
- Chain surface: Phosphating (black)
- Chain Guide: Precise chain guide with 5-pocket chain wheel
- Chain falls: 1
- Chain bag: 1 textile chain bag, detachable, ≤30 meters
- Clutch: Patented friction clutch for overload protection
- Full load noise level (db): ≤60
- Brake: 2 DC brakes
- Load hook: 1-fall / turnable
- Suspension: suspension ring
- Mounting position: climbing & stationary
- Plastic handles: without
- Protection level: IP 66
- Weight without chain (kg): 31
- Motor power (KW) : ca. 1.1
- Current consumption (A): ca. 2.7
- Mechanism class /FEM9.511: 1Bm/ 25% ED
- Color: black, RAL 9005 matt

OPTIONAL:

- **Electronic limit switch, optional**, internal adjust mechanical rotation electronic limit
- **Electronic limit switch, optional**, directly adjust the up and down electronic contact limit switch(See Figure 8,P11)
- **Encoder, optional**, install incremental encoder or reserved encoder installation position (low-speed sprocket output shaft or high-speed motor shaft)
- **Suspension method, optional**, swivel hook(See Figure3,P6)
- **Weighing detection, optional**, load cell
- **Chain surface, optional**, galvanized(white)

电动葫芦尺寸表/ELECTRIC CHAIN HOIST SIZE

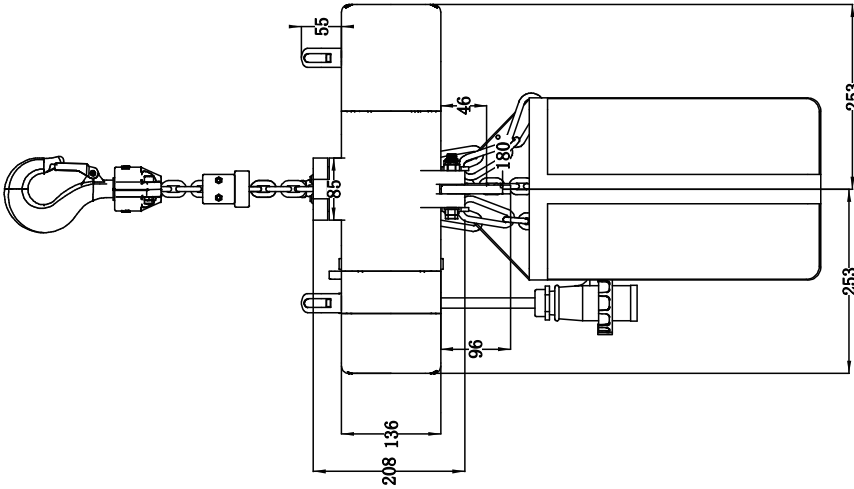
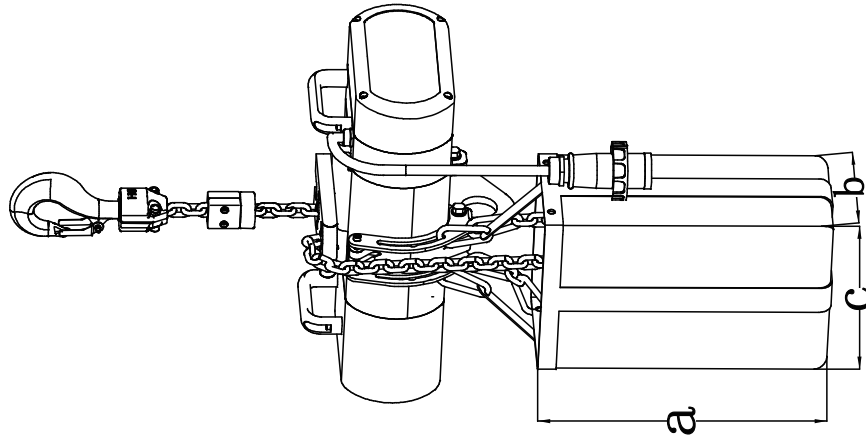

链条袋规格/CHAIN BAG SPECIFICATION			
链条长度 CHAIN LENGTH(m)	链条袋尺寸/CHAIN BAG SIZE(mm)		
	a	b	c
10	400	180	250
15	400	180	250
20	500	180	250
25	500	180	250
30	500	180	250

注：单位mm/Note:Unit mm

图1/Figure 1

吊挂组件/OPTIONAL HOOK ASSEMBLY

图2/Figure 2

配置1: 单孔悬挂板组件
Standard 1: Single hole suspension plate assembly

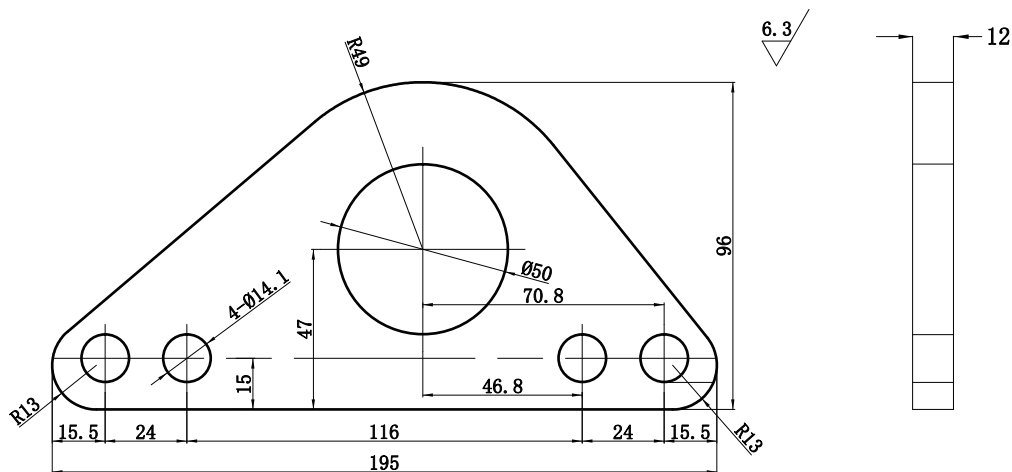

注: 单位mm/Note: Unit mm

图3/Figure 3

配置2: 360°旋转吊钩悬挂组件
Standard 2: 360° rotating hook suspension assembly

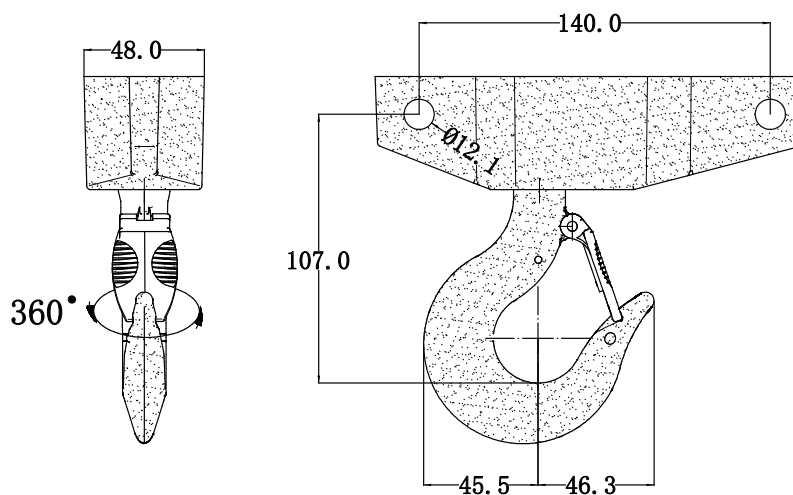

吊钩规格型号 HOOK SPECIFICATION	b1	B1	b2	B2	h1	h2	d	a1
HG-D-0.5T	5.1	17.3	5.1	17.3	27.7	23.7	35.5	30.5

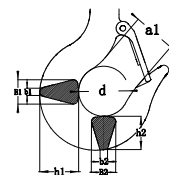

注: 单位mm/Note: Unit mm

吊钩组件/HOOK ASSEMBLY

图4/Figure 4

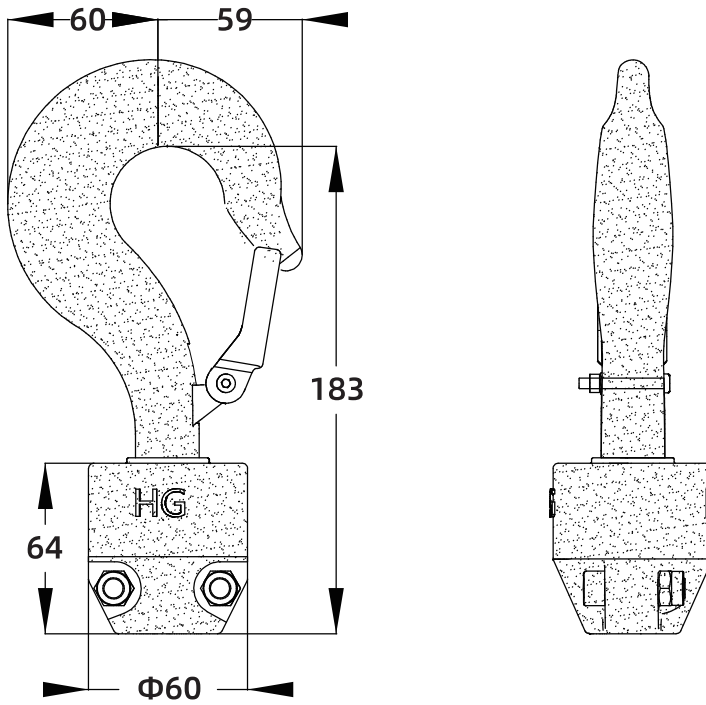

吊钩规格型号	b1	B1	b2	B2	h1	h2	d	a1
HG-D-1T	7	22.3	7	21.7	37	34	40	34

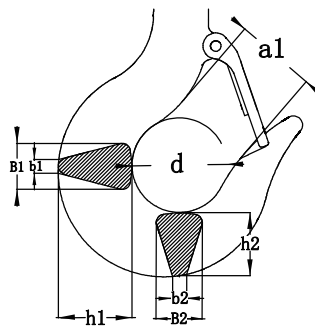

注: 单位mm/Note: Unit mm

D8 PLUS 1000

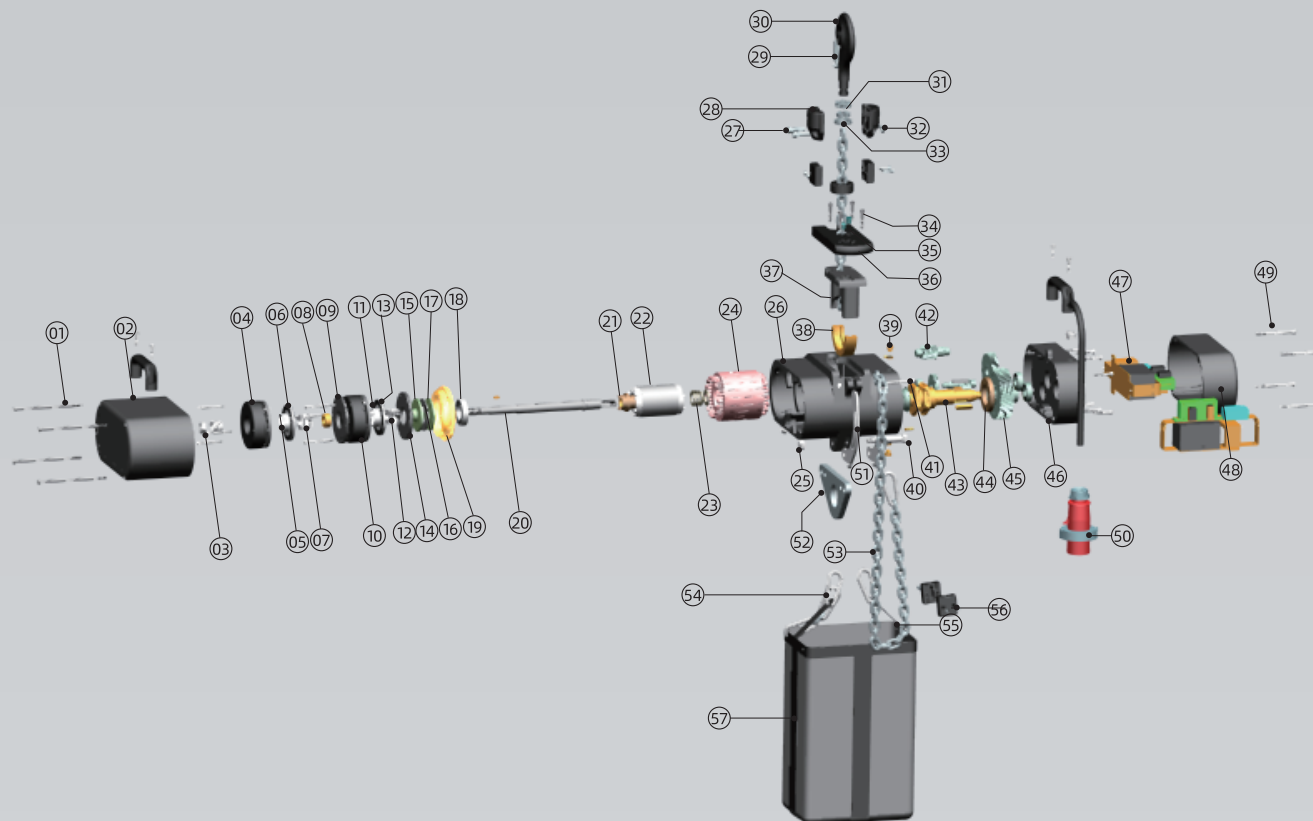

产品结构表

01 电器端盖螺丝	02 电器刹车盖	03 离合器调节螺母	04 电磁制动器	05 调节弹簧	06 制动摩擦片	07 制动齿轮	08 制动器调节套
09 制动器底板-1	10 电磁制动器-2	11 制动器调节套	12 制动齿轮	13 制动摩擦片	14 制动器底板	15 离合压片	16 制动摩擦片
17 离合上压片	18 离合压套 -1	19 制动器底座	20 长轴	21 内衬套	22 转子	23 单向推力球轴承	24 定子
25 上钩螺母	26 齿轮箱体	27 下钩螺丝	28 下钩夹板	29 保险卡	30 下钩	31 单向推力球轴承	32 下钩螺母
33 下钩两半圆固定圈	34 导链架固定螺丝	35 限位开关	36 出链盖板	37 导链架	38 护链器	39 油堵	40 上钩轴
41 螺栓	42 链轮轴承	43 链轮	44 油封	45 输出齿轮	46 齿轮箱盖	47 电器	48 电气盖
49 电器端盖螺丝	50 航空插头	51 链袋挂件	52 上钩吊环	53 链条	54 环形链接环	55 安全保护环链	56 链条锁块
57 储链袋							

D8 PLUS 1000

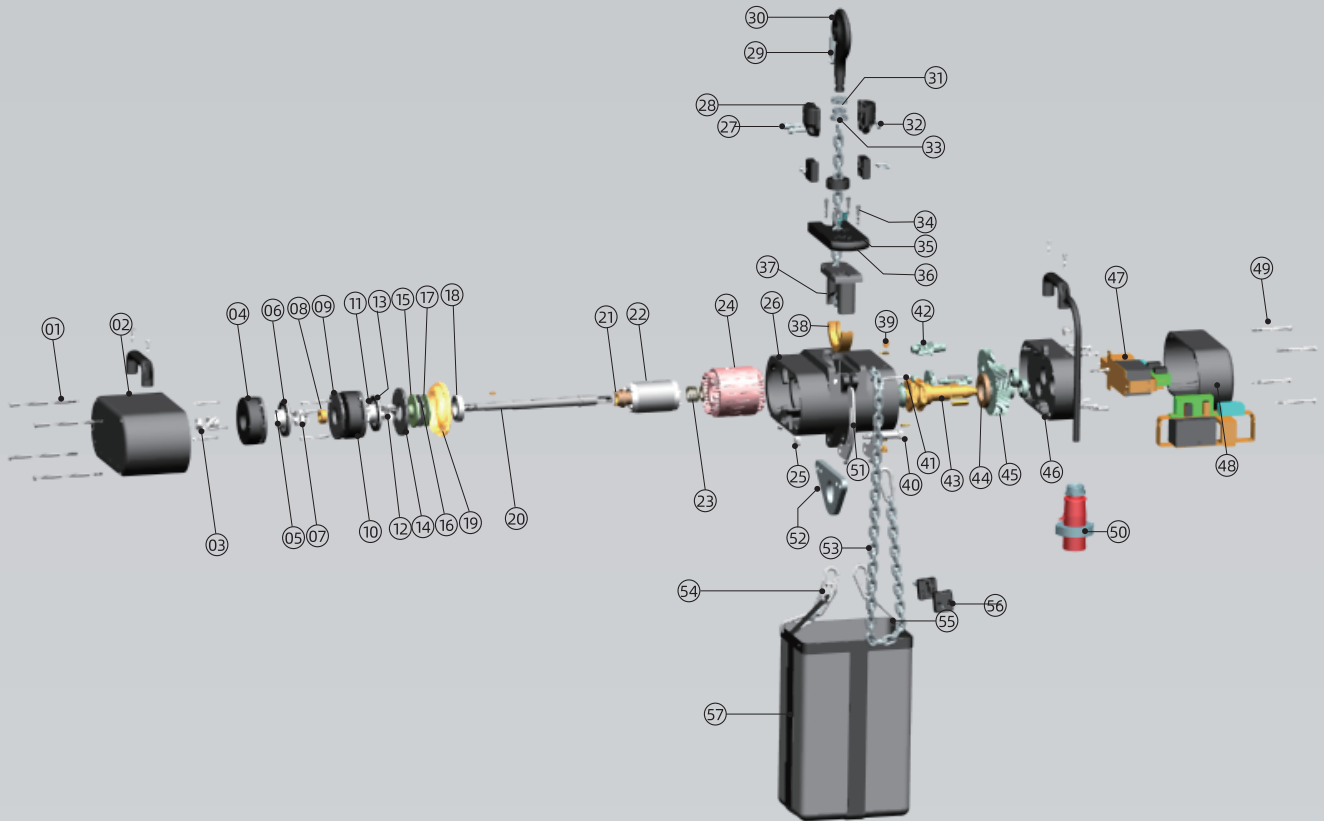

PRODUCT STRUCTURE

01 Electrical equipment cover screws	02 Electrical brake cover	03 Clutch adjustment nut	04 DC brake	05 Adjustment spring	06 Brake friction disk	07 Brake gear	08 Brake adjustment sleeve
09 Brake base plate	10 DC brake	11 Brake adjustment sleeve	12 Brake gear	13 Brake friction disk	14 Brake base plate	15 Clutch pressing disk	16 Brake friction disk
17 Clutch pressing disk	18 Clutch press sleeve	19 Brake base	20 Rotor shaft	21 Inner bushing	22 Rotor	23 One-way thrust bearing	24 Stator
25 Up hook nut	26 Gear box cover	27 Down hook screws	28 Down hook splint	29 Safety latch	30 Down hook	31 One-way thrust bearing	32 Down hook nut
33 Two semi-circle fixing rings for the lower hook	34 Chain guide fixing screws	35 Limited switch	36 Chain out cover	37 Chain guide	38 Chain guide	39 Oil seal	40 Up hook shaft
41 Bolt	42 Chain wheel bearing	43 Chain wheel	44 油封	45 Output gear	46 Gear box cover	47 Electrical equipment	48 Electrical cover
49 Electrical equipment cover screws	50 Flight plug	51 Chain bag pendant	52 Up hook ring	53 Chain	54 Ring link	55 Safety protection chain	56 Chain lock block
57 Chain bag							

电器线路图/Electrical wiring diagram

直接控制-单刹-3ph/High voltage directly control-single brake-3ph

图5/Figure 5

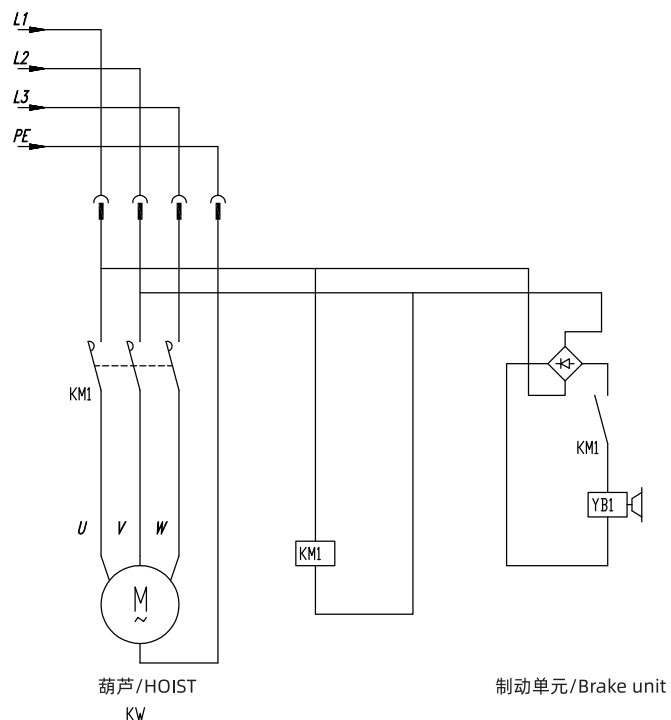

注：不带限位/Note: without limit switch

直接控制-双刹-3ph/High voltage directly control-double brake-3ph

图6/Figure 6

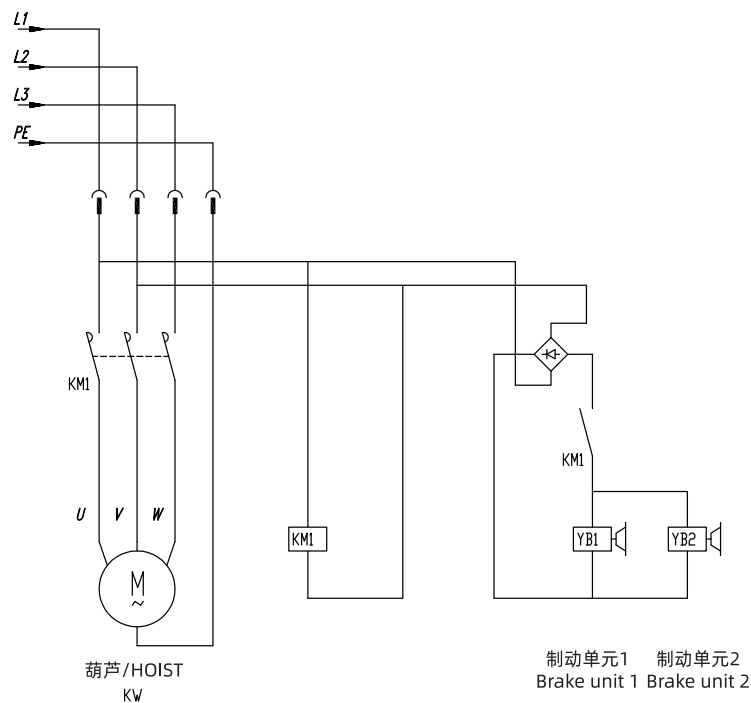

注：不带限位/Note: without limit switch

电器线路图/Electrical wiring diagram

